

HSAjet CU USER MANUAL



A guide to operating and managing the HSAjet CU print controller

Last update 11 Sep 2007

Introduction

Congratulations on the purchase of an HSAjet CU unit. You have a powerful stand-alone controller with features comparable to PC-solutions. With full remote control, on-line editing of content, security features and simple operation, this unit is suitable for many different applications.

For proper care of your unit, you should observe the following guidelines :

- ⚠ Do not unplug any cables while the unit is turned on
- ⚠ Do not take out the compact flash card while the unit is on
- ⚠ Do not take out cartridges (HP model) while the unit is in print mode
- ⚠ Preferably you should shut down unit properly before turning off power. This will correctly close any open files on the compact flash card
- ⚠ You should make sure the CU does not get in contact with water. It is not under IP protection.
- ⚠ Never remove the back panel with power on, on the CU or power supply, while the power is connected. Shock hazard!

⚠ IMPORTANT

The compact flash card is inserted BACKSIDE UP, as illustrated here.

NEVER try to insert otherwise, and do NOT use force to insert CF card. You may break the card connector, resulting in replacement of motherboard.



Copyright and Trademark Information

Microsoft, and Windows are US registered trademarks of Microsoft Corporation.

HP is a registered trademark of the Hewlett-Packard Corporation

This and other literature on HSAjet products is © HS Automatic ApS 2005-2007. You may freely use this instruction and translate it, as long as you do not change the content.

Features of the CU

- Print using normal printers, xaar- or HP based.
- Messages stored on standard Compact Flash cards.
- Variable text, date, clock, counter and barcode
- Prompt input of variables, 80 characters per line
- Print height 140 mm (Xaar) / 50,8 mm (HP)
- Separates message design and use
- 16 different fonts for variable objects, selectable among all windows fonts
- Input of all Latin-1 character set directly from unit
- Security features available to avoid unwanted editing of messages
- Ethernet connection / serial connection, allowing full remote control of unit
- Bidirectional print supported (**beta**)
- HP cartridge parameters supported (**beta**)
- Variable objects in other codepages changeable via RS232 (**beta**)

Version Numbers

The CU software comes in an official version, and several beta versions that eventually will form the next official version.

Official Version

supported and bugs are corrected as soon as possible. No new features are added.

CU release	2.00	Firmware version 020
INKdraw version	1.8.25	
Language Editor Version	1.5	
Language File Information	1856 byte	MD5: B8885DEEEB1DB9DCE222B9112C779FD4

Latest beta version

New features are added, but should NOT be used for production environment unless after thorough testing in-house. These features are marked (beta)

Bugs are corrected, but NOT in specified time or as a priority.

Suggestions for new features are welcome.

CU release	2.07	Firmware version 027
INKdraw version	1.9.66	
Language Editor Version	1.5	
Language File Information	1856 byte	MD5: B82496E16D9CC1A6010987CC682A3F75

Connecting your CU

How you connect your CU depends on the type of CU you have. Please see this guide for instructions on how to connect your unit.

In general:

- External Power supply connects using the 15-pin cable supplied with the unit
- I/O and encoder connects using 9-pin SUB-D. Please see reference section for pinouts. It is optional to use an encoder, but strongly recommended for best results.

HP version

1 pen	Use "Head 1-4" to connect first pen
1 + 1 pen	As above, and use "Head 5-8" for second pen
2 pen	Connect bottom pen to "Head 1-4" and top pen to "Head 5-8"
2 + 1 pen 2 + 2 pen 4 x 1 pen 3 x 1 pen	You need the SCSI splitter box for CU. (available separately) Connect the splitter box to the SCSI connector, and from the splitter box outputs (25-pin SUB-D) connect cables to the print heads as normal. In your layout, select as normal, do not select
3 pen	Connect to SCSI connector. Do not use 25-pin SUB-D connectors. Make sure to select "1 x 3 pen (38,1mm)" in layout, not "3 x 1 pen"
4 pen	Connect to SCSI connector. Do not use 25-pin SUB-D connectors. Make sure to select "1 x 4 pen (50,8mm)" in layout, not "4 x 1 pen"

Xaar 128 version

The first four engines (4 x 17,5mm or 2 x 35mm or 1 x 52,5mm or 1 x 70mm) connects to "Head 1-4". If you have more than one ink supply to control your 4 engines per output, you may chain them together.

You may connect "Head 5-8" similarly, for a total of max. 8 x 17,5mm print engines.

Max print height is 140 mm.

Xaar 500 version

Each connector "Head 1-4" and "Head 5-8" can connect 1 Xj500 printer.

Max print height is 140 mm.

The CU keyboard



Used to start print activity



Enter the setup menu



Enter the previous menu or go to main menu.

Stop print activity



Shift key. Use for capital letters and with **SETUP** key to enter extended setup



Space key, and ALT key. Hold and press letter key for special characters.



Arrow keys, use with enter to select message navigate in menus.



Up/down to select menu screen, or to select values in edit mode.



Left / Right to navigate menu points within each screen.



Enter toggles edit mode or accepts a choice



Object keys that allow editing of the 6 different object types

In order as they appear:

Text, Barcode, Clock, Counter, Date, Logo



Designing CU pictures

The CU pictures are designed using the OBJ INKdraw software. Please see OBJ INKdraw manual for help on installing.

Concept of CU objects vs background

In a CU image, you have both *static* and *variable* content.

The static content has no limitation, which means that you can design using any font size and have all the barcodes available. You are also rotate text, and span text across all heads available. It is not changeable once the CU file is made.

The variable content (CU objects) are placed on top of the static content. The variable content can change during print, and can be changed by the user. There are some limitations on what you can do with this object type.

Notice that in all cases, both variable and fixed objects are optional – you can design an all-static or all-variable layout, or create a mix with both.

When you use variable objects, these will always be on top of static objects.

Please find a comparison below between variable and fixed content:

Feature	Static Objects	Variable Objects
Can change automatically during print	NO	YES
Scales freely	YES	16 different fonts available, these scales freely
Position in message	Free, any position	Vertically limited to fixed position relative to 32-pixel steps. Horizontally free position
Rotates	YES	NO
Spans heads	YES, fills entire message	NO, can ONLY print within head boundary. HP: max 12.7mm high.
Editable	NO	YES
Font type	All available	Selection. Latin-1 type editable on keyboard. Others only by remote control
Length	Unlimited	Depends on object type. Text 80 characters. Dates / clocks 10 characters in output format
Object types available	Only text, graphics and fixed barcodes. No objects that auto-update, like date, time...	Text and auto-update objects. Both can be displayed as normal objects or barcodes
Mandatory	No	No

As long as you are designing your picture in OBJ INKdraw, you can change both the background and variable content. Once you compile the CU file (save it to compact flash drive as a CU file), you can only edit the variable objects, on the CU unit itself.

Start a CU picture

To start a CU picture, choose File->New on the menu, or click the "New File" icon. You will be presented with a menu where you select the file type.

- Select "Head type". You should select the same type of head as your CU unit is made for, you can't load other file types.
- Check the "CU" option.
- Add the heads as necessary with the buttons below. With XaarJet500 you will only have 1 size to choose from. You are only allowed to add as many heads as the CU can handle.
- Select the message length. You can change the unit between mm/inch/pixel/point.
- Click OK

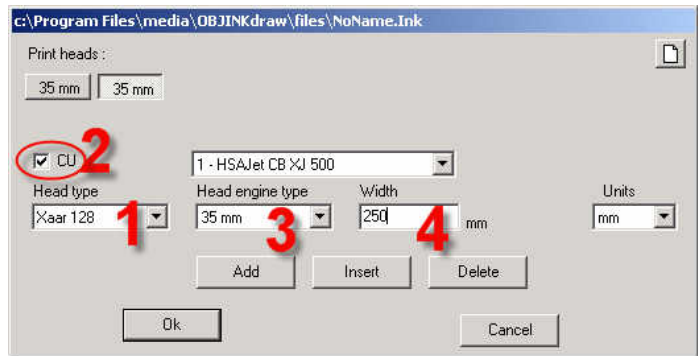

Once you have clicked OK, you are presented with the edit screen for CU files. Most of the screen is identical to normal OBJ INKdraw pictures, but there are some differences.

Most importantly, a lot of the buttons are gone, and you see that there are 6 different CU objects available, and that these are placed on the canvas by *anchors* (please see below). You will also see the "CU Mode active" indicator right above the object panel.

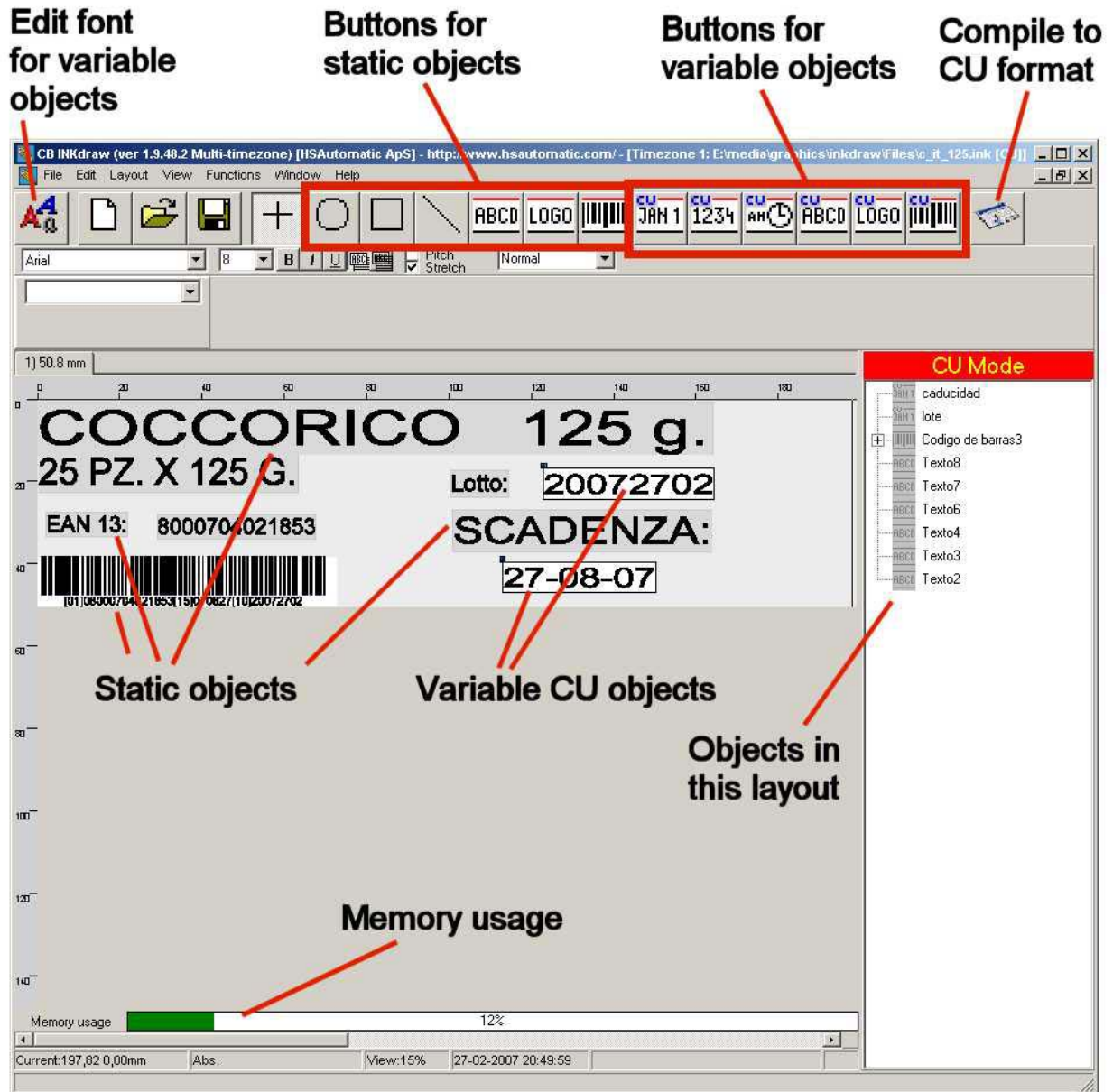

Working with font types / anchors

The variable CU objects, except the logos and barcodes, display textual information. Because of it's resources, the CU is not able to place and scale fonts freely. That is why the *font anchors* were made.

For every CU message you can choose up to 16 different fonts, each linked to an anchor with a different color. Within each of the 16 fonts, you can choose between font type (Arial, Courier, and every other installed true type font), a font size, bold - you can even stretch the font freely.

Within each anchor, you can change the font offset from top to bottom.

An *anchor* is defined as 1/4 of the XJ128 head, equal to **32 pixels**. You can place the anchor freely in the print direction (left/right), and in 32 pixels increments in the vertical direction.

Some illustrations will show the point of anchors:

Here is a purple and yellow anchor, with the same font but different offsets from the anchor.

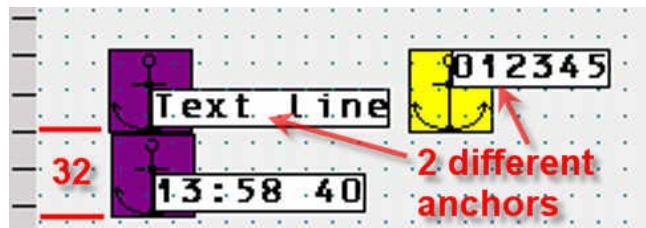

You can see that the same anchor always displays the same font. If you change an anchor font definition, it will affect all variables with that anchor color.

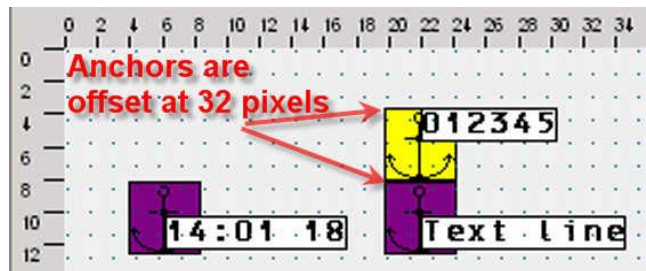

To smaller make text lines closer together, use two anchors. The anchor itself is only visible in design mode. They are not printed.

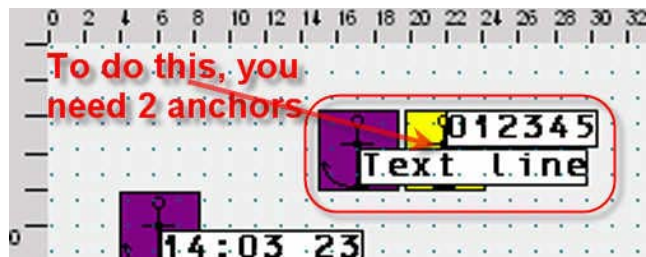

It is not a problem to define a font that is larger than the anchor itself.



To edit the anchor definitions, click the "A" button next to the anchor selector.

This will open the font editor. Select the anchor you wish to edit, and change the font as needed.

You can leave the default name (Name size (offset)) or make your own like "my big font"

Click "Close" when done.



CU file sizes and fonts

The most space-demanding part of the CU files are the font files.

If you do not change any font settings, the CU files will occupy about 1-2 Mb on the CF card, depending on the head type.

Notice that larger fonts increase the CU memory use. For example, a 70mm high font on Xaar500 will increase the font file to about 12 Mb. It is recommended to use smaller fonts.

Preventing object editing

Sometimes it is necessary to prevent objects in the CU from being edited. This is possible by locking the object in OBJ INKdraw before you compile the CU file.

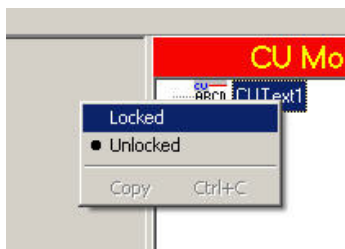

To lock objects, **right-click** the object in the object list and select "Locked". Now you can no longer select the object in OBJ INKdraw canvas, and you can not edit in the CU.

If it is desired to *allow* editing, but *only* after entering a password, set a CU password in the preferences menu. Then you can use the same password to edit locked objects. Unlocked objects can always be edited.

CU Objects

The CU has 6 different variable objects. All of them are editable directly on the unit itself by pressing the corresponding object type key.



Dates

You can have a total of 10 different date objects, each with a user-defineable format and individual offset.

The format follows the standard codes such as "dd", "mm" and "yyyy", although the number of codes available are limited. You can choose from a pre-defined format, or type in your own string.

Month names are available, and changeable in the language file. Use mmm, Mmm and MMM for month names.



Counters

A total of 10 counters is available, each with a user-defineable start- and step value



Time

Allows 10 different clocks, each with a different time offset.

The clock is in 24-hour format, 12-hour format is currently not available.



Text

Up to 10 different text lines.



Logo

10 different logos are possible. These can be placed anywhere, and are not limited to the position of an anchor.



Barcode

10 different barcodes are possible. At the moment, human-readable text is not supported, but will be added later.

The barcodes can contain variable information in the shape of either text, counter, date or time. It is not possible to have a barcode with multiple variable objects.

Notice that barcodes count against the 10 object limit in the respective object types. So, if you have 5 counter barcodes, you can only have 5 normal counters.

Non-English characters

Normally, when you enter information into textual objects, the character set is Western (English). This means that other character sets will not display correctly.

If you need to use different character sets, you can specify – per object – which character set you use.

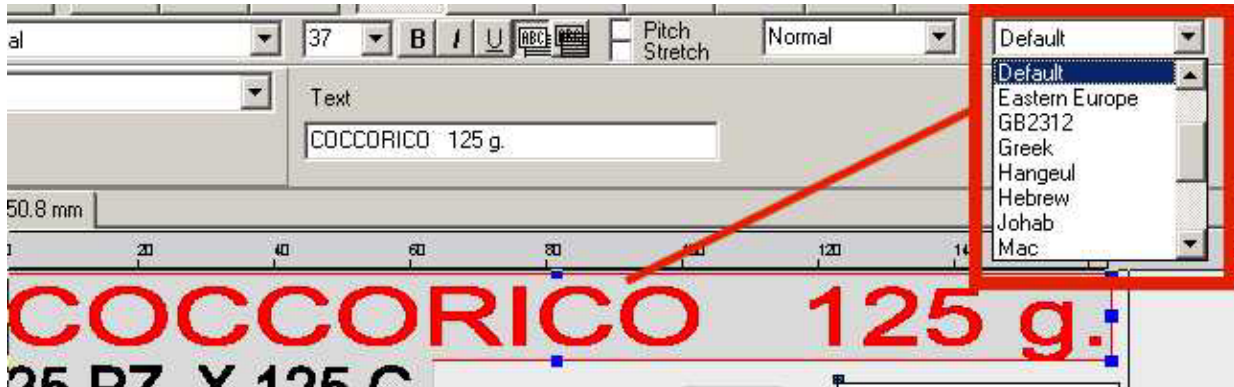

Click on the object, and select from the dropdown right-most in the screen, under the CU object buttons. You can choose from a number of character sets.

The difference can be seen with a small demonstration. In this example, the actual text of the object was not changed. Only the character set.

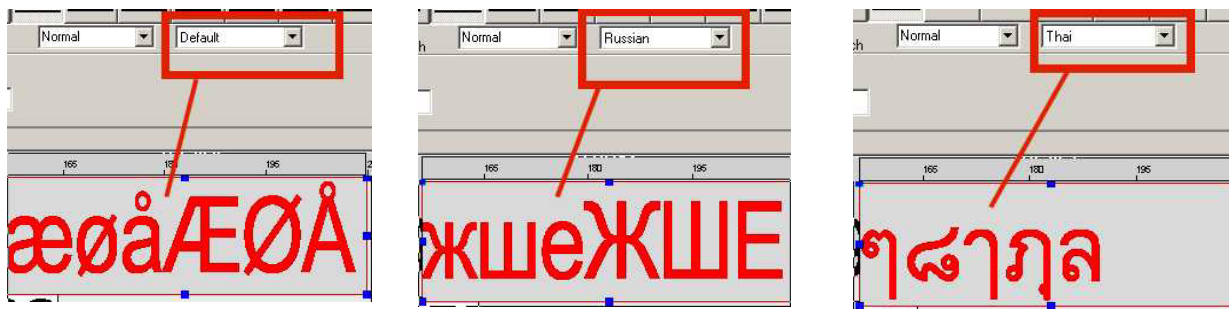

Default (Western Europe)

Russian

Thai

Notice:

if you wish to use Chinese, Japanese, Thai, Korean, Vietnamese or Arab character sets, you should have the proper input software installed in your PC.

Compiling / saving files (to CF)

When you are done editing your image, you need to compile the ink file to use it in the CU.

As this is a one-way process (i.e. you can not edit CU files later in OBJ INKdraw), the user is recommend to save the .ink file along with the CU files.

The CU files are made of 2 individual files that are both required: A CU file with object data, and a FNT file with the font data.

NOTICE : On the CU, you only need to change parameters for HP resolution while editing your message. All other parameters are set on the CU unit itself.

You can however store a file on the CF card called "CUPARMS" containing parameters from your current message - then upload to the CU. Do this in the "Advanced mode" below.

HINT : It is possible to save directly onto the CU using ethernet connection. Please see later chapter about this.

- Click the "Save to CF" icon.  This will open the Save dialog box.
- Select the compact flash in the disc dropdown. You can also choose to save on the harddrive, and copy the files later. (not recommended)
- Enter a filename. It is a good idea to save the ink file along with the CU file, since you can't edit CU files from OBJ INKdraw.
- It is a good idea to check "Auto-eject CF" if you are not going to save more layouts on the card. Otherwise, the file system on the card may be destroyed.

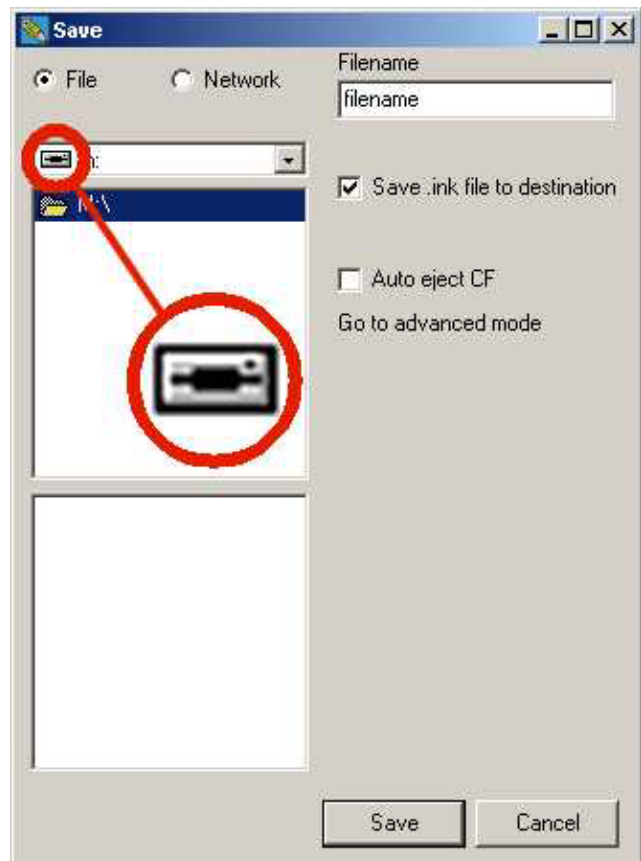

Saving files to PC network

If you have your CU connected in a PC network, you can save directly onto the CU unit. INKdraw will upload the file for you.

To use this function, you must know the IP number of your CU, see in the shift - setup menu how to check the IP number.

Then follow this procedure:

- Click the "Save to CF" icon.  This will open the Save dialog box.
- Select the "network" option
- Enter a filename. You can use the same name again if you only are interested in transferring new data, the old file will simply be overwritten.
- Enter the IP number, in the form
- Optionally you can load and / or print the file after upload to your CU.

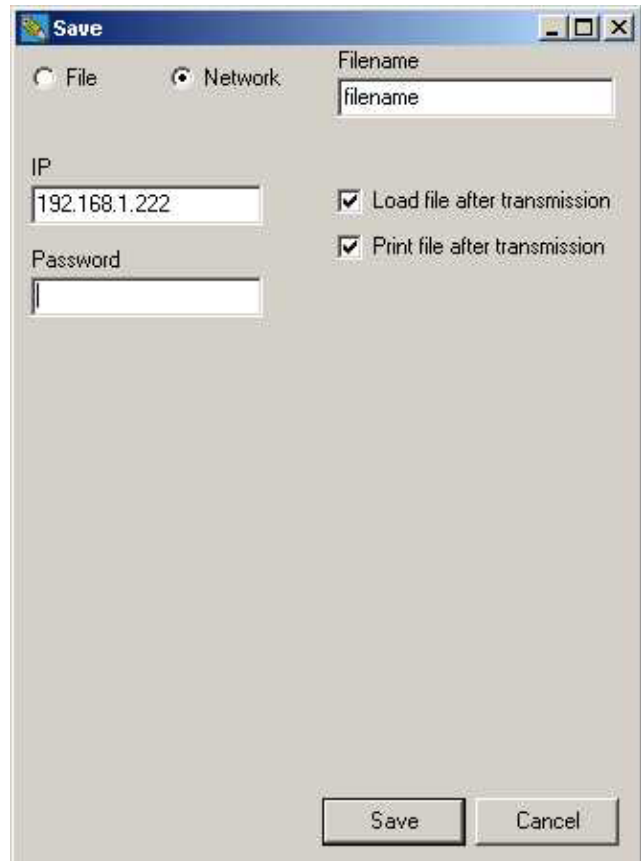

Using the CU

After you have saved the file to the CF card, you must insert the card into the CU.

CF cards are ALWAYS inserted BACKSIDE UP, CONNECTORS IN.

DO NOT TRY TO FORCE THE CF CARD IN WITH TOP UP, YOU WILL DESTROY YOUR CONTROLLER.



The idea of the CU is a unit that will allow the user to select messages and print them using the standard HS Automatic printers – xaar or HP.

The messages are stored on the compact flash, and can be recalled by simply selecting the filename from the main menu and pressing enter to load.

In each message, there can be both static and variable content. All variable fields can be edited by pressing the corresponding object type key.

Basics

You have two different "cursor modes" in the machine: editing and moving. When you enter a menu, the cursor is in move mode. From here, you use the arrow keys to move between menus, commands and fields.

If you press enter on a field, you will activate edit mode

Edit mode

- *Enter* activates your selection or starts edit mode.
- *Esc* cancels the editing
- *Insert* toggles between insert / overwrite
- *Delete* removes the character under the cursor
- *Arrow up / arrow down* chooses the values just above / below the current.
- *Alt/Space with some letters* will type european characters (Latin-1), such as á, ø, ú...

Navigation

At any point it is possible to jump directly to other sections by using the object keys. If you are in edit mode, this is considered as ESC. For example, you could have finished editing a text object, then it is possible to jump directly to date editing by pressing the "Date object" key.

Password protection

It is possible to change setup values (print parameters) from the unit, but this menu can be protected by a password.

Print function

Activate the print function with the  key. The red LED in the key will turn on if the print mode is active. Use ESC to stop print mode.

During print you can adjust the start distance with the arrow keys

```
Printing > 00000
(ESC) 000.00mm
```

- 00000 Number of prints with this picture. Is reset when a new picture is loaded.
- 000.00 Start delay. You can adjust by using the arrow keys, ◀, ▶, ▲ or ▼. (decimals)
- mm Units for start delay (mm / inch)

Prompts

When the print mode is activated, there can be prompts set on one or more objects. Prompts is a way to ask the user to enter information that will be a part of the print, typically a best-before date or batch number.

Prompts are shown with the object name and room for editing. It is possible to activate prompts for the following objects:

- Text (string). Max 80 characters.
- Date (input format chosen in OBJ INKdraw preferences)
- Time
- Counter (start value)
- Barcode (variable object inside).

```
Tekst 1
XXXXXXXXXXXXXXXXXj_
```

```
Date 1
11-05-2005_
```

Editing is cancelled with ESC, which deletes what is written. ESC again will cancel print start.

Navigation in prompts is done with the arrow keys. Use up/ down to jump a full screen if the text is longer than 16 characters.

Main menu

You reach the main menu from any menu by pressing ESC.

The main menu is where you select the message to print.

```
Orangesxxxxxx
Choose file.
```

or, if the current file is the active:

```
Test1
File selected
```

To load a file

It is simple to load a file. Use the arrow keys to browse the available files stored on the CF card, or start typing the file name. Predictive type-ahead will find the best match for you.

When you have reached the correct file name, press enter to load it. You will see the text below the file name change to "File selected."

If you try to load a file that is not made for your unit, you will see a warning that you can't use this file.

```
XJ128 files are
invalid on XJ500
```

XJ500 files are invalid on XJ128
HP files are invalid on XJ128
HP files are invalid on XJ500
...

Shutting down the machine

When you wish to shut down the CU, you should exit properly to minimize the risk of file damage on the Compact Flash card.

Press ESC from the main menu, and you are asked

```
Do you want to
shut down? Y/N
```

Press Y to shut down the CU unit or N to continue.

Shortly after you see

```
Its now safe to
turn off the CU
```

.. and you can turn the unit off on the power supply.

Editing object / message content

With the CU, there is a separation between content and design. While it is possible to change the size and position of objects in the design phase, this is not possible on the CU unit itself. Only the following can be changed.

- Content - except for logos.
- Visibility (on/off)

You edit the object by pressing the corresponding object button. This can be done at any time, even in print mode. (Notice though that there is a buffer of 2 prints, changes in print mode do not happen instantly).

When you press an object button, you are presented with a list of objects of that type. If none are found, you receive a notice about this:

```
Counter:
No objects (ESC)
```

If objects in the category exist, you will see a list of objects, arranged by their order of appearance in INKdraw. Choose object with **↑** and **↓**.

When an object is selected, you see its value and on/off setting. Use cursor **↵** to move down from object name to edit field, and press Enter to edit value.

```
Counter 1      On
00000045
```

Notice: If the object name has **(Bar)** written next to it, it is contained inside a barcode. You can then only see its content, and need to edit it through the barcode menu. Please see the “special case” section on next page.

What you see will depend on the object type.

```
Date 2      On
20-12-2006
```

```
Prod.time    On
13:44
```

```
Text 1      On  x
The quick brown>
```

← and **→** will move 1 character
Shift ← / → will move 1 screen

As you can see from the example to the left, the text

```
The quick brown| fox jumps ove|r the lazy dog
```

is longer than one screen. You can scroll longer messages by using arrows up/down.

Selecting "X" deletes the entire line content.

```
Text 1      On  x
< fox jumps ove >
```

```
Text 1      On  x
<r the lazy dog
```

After a change, you are informed about the change.

```
Value accepted
(ENTER)
```

Enter returns you to the object list.

Special case: Barcodes

If you choose a barcode, the format of the content will depend on the content type (Text / Counter/ date / time).

When you select the barcode, you can choose between the available barcodes with arrows up/down. Then move the cursor with arrow right and press enter on "Edit content".

```
Barcode 1   On
Edit content
```

You will now see the edit screen for the content of the barcode

```
Counter1   (Bar)
0000002
```

Once you are done editing the content, press ESC to exit to the barcode screen, or one of the other object type keys.

Input pictures for object types

Text	String, max 80 characters Scroll using up/down. Input of special characters possible.
Date	Numbers, from an input mask. The input mask is selected in OBJ INKdraw. You do not need to enter separation characters. Ex: 14-04-2005
Counter	Current value, entered as a decimal value. The number of digits can not be changed. Ex: 0000000
Barcode	Depending on the variable content.
Logo	Only visibility on/ off is possible

Input of special characters

To enter special characters like 'ä' and 'ü' you hold down the **space** key (Labelled "Alt") and press the key where the character is printed.

Similar characters are grouped on the same key, like on a cell phone, so that for example repeated pressing of



will toggle through the following

á Á ä Ä å Å à À â Â ã Ã

The CU is able to print almost all extended characters in the ISO Latin 1 character set. ISO Latin 2..15 is currently not supported in variable characters.

Please see reference section for a list of all characters and what key to use.

Configuring your CU

On the CU, most settings are made directly on the unit itself. This means that in the design phase, the designer can and should focus on *design* only. The operator / service responsible can and should focus on *hardware* only – setting the offsets and parameters correctly.

The configuration of the CU happens in two menus:

Setup	which is mostly related to the logical functions of the CU: offset length, encoder parameters, etc. This is also the menu where you can set the date/time of the unit, and get version information.
System setup	which focuses more on the <i>hardware</i> part of the setup: how the heads and engines are positioned in relation to each other and the start sensor. Ethernet parameters are also set here. And, this is where you set a password for the CU.

In both cases, the setup menus are working a several screens that are located below each other. The navigation between screens are with cursor up/down, within each screen with cursor left/right.

As always, press enter to start and end edit mode, and to toggle values.

SETUP MENU

Press the setup button  to change settings that affect mainly the current file.

In setup you have a series of menus that can be navigated with the arrow keys. At any point, press ESC to return to the main menu.

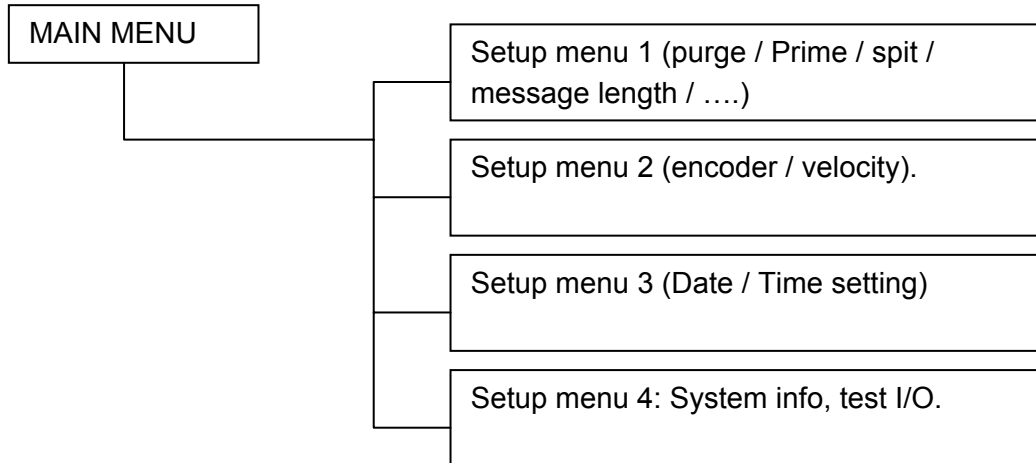

Setup Menu 1

On the CU, hardware settings like start, offset, direction and encoder settings are generally *not* taken from the design software, but used from the machine's own settings. You can load a Hardware setup, but until you do that, all settings are as set on the CU unit.

```

Purge Spit +
Start 000.00 mm
    
```

Purge

The purge function (shooting on all channels) is activated with ENTER. You purge as long as you hold down the key. Release to stop purging.

Spit settings

Spit function is made to prevent the ink from drying in the head. It can be set to print *n* dots (burst) every *x* seconds, on all channels.

```

Secs 00 Burst 00
    
```

Seconds Time between each shot

Burst The number of shots

Start distance / unit / sensor

000.00 Start distance (1/100" or 1/100 mm).
Max distance is 655,35 mm/ Inc.

mm/ In Toggle between mm and Inches. The units will be converted

+ Start sensor pos/neg edge

Setup Menu 2

This section describes the printer settings. Setup menu 2 is the most basic settings for the printer, that will have affect on this message.

```
Direction <
Enc 0, 00000 Qua
```

Qad = Quadrature
Lin = Linear

```
Direction >
Vel 000.00 m/min
```

Display changes if
you select Velocity.

Print settings

Top row is used to choose direction. Toggle with enter.

Encoder

Enc is a toggle that selects between encoder and velocity modes. The value when encoder is selected is written just like in OBJ INKdraw – mm/pulse.

Qua is a toggle for Quadrature (sensing on both channels, equal to 4 times the number of pulses. Qad = Quadrature, Lin = Linear.

Velocity

In velocity mode, the encoder parameters are not available, only the speed can be entered as m/minute.

Beta releases allow you to input 2 decimals for velocity.

4.8.3 Setup Menu 3

```
Endless Y Rep 00
Distance 000.00
```

Endl. Y Toggle, endless. Y/N

Rep **00** Field, indicates repeat. 00 = no repeat.

Dist **000.00** Field for distance between repeats – also in Endless mode. Enter in units selected in first setup screen. (1/100" or 1/100 mm).
Minimum distance is equal to maximum engine + head offset. Page printing only possible where there are no offsets.

Time, date & year

The CU has a real-time clock built-in. The time and date of this determines the output for date objects.

You can set the current date / time in this menu, in the format YYYY-MM-DD HH:MM (24-hour clock).

You can see which part you are editing in the lower right corner, to avoid confusion between month/ day.

Press ENTER on the part you wish to edit, then enter again to accept.

```
2008-05-31
16:58      year
```

Setup Menu 4

Test I/O

Second last screen is used to test the I/O function - encoder and start sensor.

```
Encoder /
Start signal ↑
```

The encoder rotates the bar next to the word (/ | - \). Start signal switches between 2 arrows. ↑ = high, ↓ = low

About-menu

Finally there is the about-menu. Mostly for internal use, for identification of the Firmware and Hardware versions.

```
HSAjet CU XJ500
Release 1.01
```

If you press Enter on the word "Release" you will see further information about FPGA and uP version. (**This extra menu is not included in beta versions**)

These numbers (Release, FPGA and uP version) are needed to HSA if you find a problem with your machine.

```
FPGA: 2.0.9
uP:1.16      (ESC)
```

System setup

In system setup, you change the settings that are *not* related to the individual message, but are more hardware related.

Press and hold SHIFT , and press SETUP 

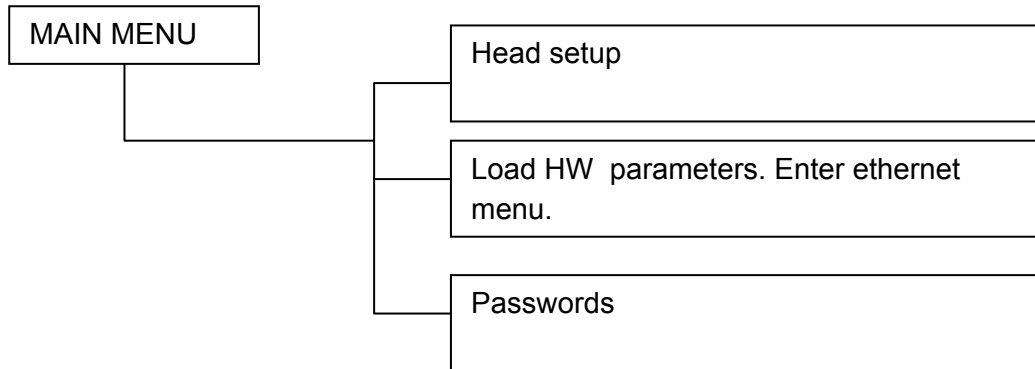

Head setup

The CU is not born with a setup of heads. You can take the unit and connect it to different configuration of printers.

The number and types of heads is stored inside the CU message and defined from INKdraw, but you can adjust the head offset and engine offset to suit your needs.

When you enter Head Setup menu you see a list of the heads configured in the message, listed with the number of engines per head in brackets. The total number of engines can not be more than 8.

XJ500 [1]

On an XJ500 machine, one head has been set up

XJ128 [1][2][1]
[4]

This is an XJ128 machine with 4 heads: 1, 2, 1 and 4 engines.

To change the settings for a head, press ENTER.

```
Head <>000.00Inc  
Adj Ups N Oths N
```

0000.0 Offset for the head.

Adj Press Enter to adjust the engine offset(s). Only available if the head has more than one print engine. See below.

Ups N Is this head printing upside / down.

Oths N Is this head printing on other side (in reverse direction)

Engine adjustment

Engine adjust is available if the head has more than one print engine (XJ128 for 2,3,4 engine heads, and HP with 2,3,4 stall unit)

```
Eng. 2  
Offset 00.000 mm
```

Select an engine (1..4) and choose settings

Offset Offset from the first engine in the head.

Managing Hardware parameters

Ink size/usage and Ethernet Setup

On the CU, all printing parameters (except HP resolution) are stored on the controller, not the message that you load. This ensures that you only have to focus on layout, once the parameters are correct.

It is possible to store the settings from OBJ INKdraw and save to the CF card. These settings can be loaded from the HW global setup screen.

From OBJ INKdraw select "Advanced Mode" in the save CU screen, and click "Save Hardware file". This file will be called **CUPARMS** and should simply be placed on the card.

```
Ethernet Ink
Load HW settings
```

Ethernet Setup

To use the machine in a PC network, you should configure it's settings in the network.

```
DHCP Off      IP:
192.168.002.120
```

```
Devicename:
CU Device 1
```

Notice that you can not edit IP address if DHCP is on, since it will be achieved automatically. 000.000.000.000 until address has been assigned by DHCP.

USE PORT 1500 to communicate with the CU

- DHCP If this is set to ON, the machine will expect to find a DHCP server in the network, to automatically obtain an IP address.
- IP If no DHCP server is used, the machine will use this IP address.
- DeviceName The name this machine will have in a network. Only shown with command to get device name (REQ:device name#)

Ink menu

In this menu, you can set the size of your ink container and monitor how much ink has been used. This is also where you reset the value after replacing ink container.

```
Monitor Warn 000 ml
Mode: user 000 ml
```

- Monitor Select this menu to see use of ink (HP)
- Mode Choose between:

- Off (no low ink warning),
- cart 42ml,
- bulk 350ml and
- user set.

Monitoring the ink menu

```
1 : 42ml      2 : ---ml
3 : ---ml    4 : ---ml
```

You can see the approx. remaining ink for each defined cartridge. Press ENTER on the number to reset.

How to load Hardware settings

If you have saved a hardware setup file from INKdraw, you can load it by selecting "Load HW settings". If a file is found and loaded, the CU will display

```
Local settings
saved to CU.
```

If you do not have a hardware file, you will see

```
File Error:
HW file missing
```

Press ESC to return to previous menu.

Output configuration

The CU has 2 outputs on the start switch, out1 and out2. Each of these can be selected to give a signal on the following: off (nothing), print mode, printing, fault, ink low(HP)

```
Out1: off
Out2: off
```

By default, the outputs are both set to "off".

Password

It is possible to protect the CU so that no-one without the password can access the parameters.

If there already is a password set, you need to enter it to change it. Otherwise, you just need to change it, and confirm it afterwards.

Password:

_

Passwd: *

Confirm *
_

**Password
changed OK!**

When you set the password, it will affect the following:

- Parameters / HW parameters are only available if you know the password
- Locked objects are editable, but only if you know the password

If NO password is set (equal to blank input on password change) the following will be the case:

- Parameters freely available
- Locked objects can NOT be edited ("Object Locked" will be shown)

Remote communication with the CU

The CU is an ideal unit for solutions where remote communication can be used to change message content. Typically behind weighing / measuring stations, or simply in complete factory automation.

The basis of communication

Communication can be both with serial (RS232) and with Ethernet, using the same simple protocol.

For RS232: **Use COM1 port.** You must use a **crossed cable** (Null Modem), and use the following parameters:

Rate:	9600 bits/second
Stop bits:	1
Data bits:	8
Paritet:	None
HW flow	None

For Ethernet: **Use device IP address, port 1500. Password is same as parameter password, if set.**

Optional : CU network search: UDP/IP port 1600 broadcast

PNG:CU#

Reply from CU's in network:

PNG:CU#000	(10 bytes)
IP ADDRESS	(4 bytes)
ENET VERSION	(4 bytes)
<0xFFFF>	

PLEASE SEE COMPLETE REFERENCE LATER IN THIS MANUAL

The communication is based on commands and response from the CU unit. The syntax is as follows: **XXX:parameter;{value};{value};...#**

where:

XXX	is a command keyword of 3 characters, upper case
:	always follows command
parameter	is a parameter to command ("which command").
;{value}	value. Not always needed, and always preceded with a semi colon
#	end of command string.

Command keywords and possible responses

This is a list of command keywords and their meaning:

CMD	Command	Basic functions such as start, stop print, connect, disconnect.
REQ	Request	Read information from the CU
OBJ	Object	Change message objects. Notice: you can only change, not create objects.
PAR	Parameter	Change print parameters in the CU
FIL	File	Send a file to the CU's flash card.

Each time you send a command to the CU, it will respond to confirm that the command has been accepted. The response, similarly, is based on a 3-letter keyword followed by colon (:) and one or more values separated by semicolon. All terminated by "#".

After every communication, you always get "RES:{error code}#", where 0 = no error. Responses may be:

RES	Result	Error / result code.
DAT	Data	Data return, for example for objects / parameters
FIL	File upload	Ready for file upload

Example of communication with CU

You Transmit	You Receive	Description
CMD:C;#	RES:10#	Remote connect with password = no password. Password accepted.
CMD:R#	RES:0#	Start print mode. Command accepted.
OBJ:1;1;CUR;0#	RES:0#	Set counter object 1 current value to 0. Counter updated.
CMD:U#	RES:0#	Update print buffer. (next print has new value) Print buffer updated.
CMD:S#	RES:0#	Stop print mode. Print mode ended.
CMD:D#	RES:0#	Disconnect. Disconnected.

Use of special functions (beta)

The CU is, like other products, under continuous development. Before they are officially released, new functions are added to the CU.

You are welcome to test these versions, and reports on bugs are welcome – but you must see this as beta functions that are NOT released for full production. If all works, good. But if not, you have been warned. We release the betas to allow you to make solutions here and now.

As soon as possible, the beta functions will be part of an official release.

To use the beta functions, you need

- The latest version of OBJ INKdraw beta software. Version number 1.9.xx, available online. Do not use this for production use with CB boards either.
- The latest beta version of CU firmware. Please check that version numbers match, and check against the language file's MD5 checksum. If in doubt, just put all files from beta version on a blank card.

Preparing for use of beta version

- Install OBJ INKdraw beta version in a separate directory on your hard drive
- Upgrade your CU with the latest beta version software

Bidirectional Print (beta)

Bidirectional print allows you to have a printhead that traverses, and prints in each direction, using the same message.

You should observe the following

- A start signal is needed in *both* directions, into the same input. The first print must be in the direction select for normal print. So printing are normal, reverse, normal,...
- There are two different start offsets, one for each direction. See below
- The time from the print is completed in one direction until the next start sensor is activated must not be shorter than 80 mSec.

To activate Bidirectional Print

The mode must be activated from INKdraw. In Preferences, select Printing, and under print buffer, "Bidirectional Print".

Proceed as normal setting up your message.

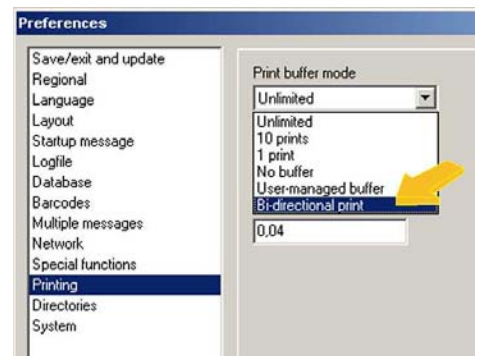

Setting start offsets on the CU

On the CU, you can adjust the two individual start offsets by changing the print direction. The CU will display a different start offset in the reverse direction if bidirectional is enabled.

Example: normal print direction is > (left to right)

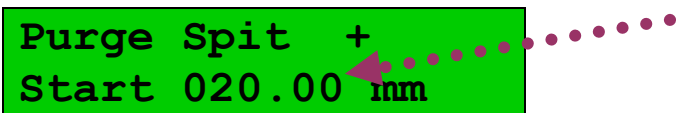

If the other direction is selected

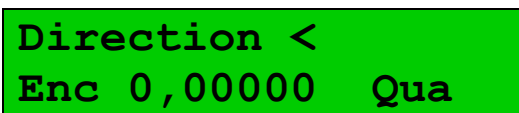

You will see and edit a different start distance

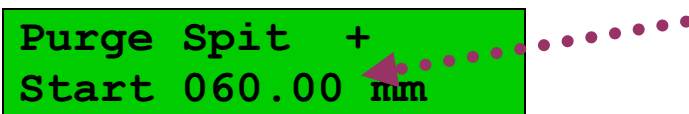

Cartridge Parameters (*beta*)

When using a PC solution it is possible to set and configure parameter values for HP. Doing so may optimize the output and quality on the HP cartridges, to adjust for each individual ink.

This option is now also possible on the CU, using latest beta version.

How to adjust HP parameters

From within INKdraw, select the parameter menu, at HP Values.

You will now have two tabs available: the first to set Resolution, the second with Cartridge Parameters.

When you generate your CU message, these parameters are automatically transferred and used. You cannot modify or view these values on the CU.



Variable objects in other character sets (*beta*)

In normal use, the CU uses the Latin-1 character set to display characters beyond the English characters set (a-z). But sometimes it is desired to display characters from other language groups such as Russian, Baltic / Slavic and Turkish.

If the information to display is fixed, no problem. Just type it in, and select proper character formatting in INKdraw as normal. The text will be printed as entered.

The issue is the strings that can, and must, change during print operation.

Your solution here is to use remote control (RS232 and / or Ethernet) and the fact that, on different character sets, a given ASCII value will translate to a different character. See this comparison table what the transmission of ASCII 155 will give:

LANGUAGE	RESULT	
Latin 1 (default)	ø	Small o with slash
Central Europe	ř	Small r with caron
Cyrillic	ш	Small letter sha
Baltic	ų	Small u with ogonek

Using these differences, you can send a string to have your words displayed in the language group you choose.

NOTICE: as of yet, it is not possible to provide a full table of the resulting characters from this conversion. We are aware about this and are working on the matter.

Upgrading your CU

Upgrades to the CU, typically new features, are released through the dealer's area of HS Automatic webpage. You can download the upgrades in the form of firmware files.

Simply place the new firmware files on the compact flash card and start up your unit.

The files needed are the following:

CUENET .XXX	ethernet firmware update
CUFIRMW .XXX	CU firmware update
CUHPFPG .XXX	CU FPGA firmware update. HP could also be 128 or 500. The unit will pick the correct file automatically.
CULANG	Language file. The length of the file must be respected (so you can't upload an old version)
KEYBCHAR .TAB	Character set for the CU keyboard
SPECCHAR .TAB	Another file for keyboard

Notice that in addition to the files above, you also need at least ONE print layout in the correct format (HP/128/500) for your unit. The content is not important.

This existence of a layout is the first thing the CU checks for.

Insert the card into your unit and start. You will see in the display

```
Tables updated
(enter)
```

After that, upload the following files (answer "Y" to upload)

```
New Firmware
Upload y/n ?
```

```
FPGA Firmware
Upload y/n ?
```

```
ENET Firmware
Upload y/n ?
```

```
New CU language
Upload y/n ?
```

When you are done, remove all firmware files from the CF card.



NOTICE If something should happen during upgrade, such as a power-out, the internal programs could become damaged. In that case, you can upgrade the unit through cable via a *JTAG*.

Please contact HS Automatic for purchase and instructions.

Reference section

Language update

It is possible to change the language of the CU display, with the limitation that you have fixed length of the texts.

The editing of the language file happens with the free tool "Language File Editor" available from HS Automatic.

Please see separate manual for this tool.

To use the language you have created, place the language file on the CF card with the name "CULANG". You will be asked to upload the language.

Keyboard layout, extended characters

1	! ¿ ¡	2	"	3	#
4	,	5	.	6	&
7	/	8	<	9	>
0	= ½ ¼ ¾				
A	á Á ä Ä æ Æ å Å à À â Â ã Ã				
B	\ { } []				
C	ç Ç				
D	ð Ð				
E	é É è È ë Ë				
F	* ÷ ×				
G	:				
H	;				
I	í Í ì Ì ï Ï				
N	ñ Ñ				
O	ó Ó ö Ö ø Ø ò Ò ô Ô õ Õ				
S	ß				
T	Ƨ Ƨ				
U	ú Ú ù Ù ù Ù û Û				
Y	ý Ý ÿ				

Notice that due to display restrictions, your character may be displayed as a different character, but will print as expected.

Error Messages

File Error: CU file missing	There are no CU files on the card.
File Error: CF card full	No more room to write on the card.
File Error: FNT file missing	You forgot to transfer the FNT file. The CU layouts consist of 2 files: CU and FNT
File Error: CU file corrupt	Something is wrong with the CU file
Flash Error: FPGA corrupt	Something is wrong with the FPGA file
Flash Error: Language corrupt	Something is wrong with the language file
XJ128 files are invalid on XJ500	You are using XJ500 model, and try to load XJ128 pictures.
XJ128 files are invalid on HP	You are using HP model, and try to load XJ128 pictures.
XJ500 files are invalid on XJ128	You are using XJ128 model, and try to load XJ500 pictures.
XJ500 files are invalid on HP	You are using HP model, and try to load XJ500 pictures.
HP files are invalid on XJ128	You are using XJ128 model, and try to load HP pictures.
HP files are invalid on XJ500	You are using XJ500 model, and try to load HP pictures.
File Error: HW file missing	Can not load hardware settings without HW file.
Default restored Please Restart	
CF card corrupt or missing	Please make sure you insert the CF card during use
CF FAT error Format in FAT16	The CU can only read cards formatted in FAT 16. Fat32 and NTFS will not work.

Connectors

The table below shows the CU as viewed from the back, with the keyboard upwards.

Encoder	I/O (start)	HEAD 1
COM1 (serial comm.)	COM2	HEAD 2
POWER	PC Network (Ethernet comm)	SCSI (HP with 3 / 4 pen stall)

I/O connector

The main function for this connector is to provide the start signal, to begin print.

It is a 9-pin female SUB-D.

The wiring of the I/O connector **is required** for function of the print – you will not get a printout without a start signal.

You can use either a simple mechanical switch or a 12V photo cell for the start signal, please see pinout and connection guide in the back of this manual.

Encoder connector

This connector is where the signals for the encoder are coming in. You will notice that there are two inputs; a “normal” encoder input and an inverse input. Which one you use depends on your encoder. Active high use normal, for active low use inverse.

The use of an encoder is optional, but will improve the accuracy of your print if your conveyor varies a bit in speed.

For accurate alignment of multiple-engine XJ128 printers or HP printers, an encoder is strongly recommended.

Head connectors

Two head connectors are available for the print heads. Head1 and Head2 are both 25-pin SUB-D, you need a **straight-through cable (1:1)** to connect to the heads.

To each connector you can connect up to 4 XJ128 engines or 1 XJ500 engine or 1 HP engine.

The SCSI connector is used to connect 3 or 4 pen HP heads.

COM1 / COM2

For serial communication with the unit. Please see section on serial communication.

Ethernet connector

Through the ethernet connection, you can control the CU remotely from a PC in the same network. You can use this select or change messages or parameters.

Connector Wiring

Connectors (start, encoder, etc) wiring.

Start sensor connections

As a start sensor, you can use a simple switch, or a photo cell.

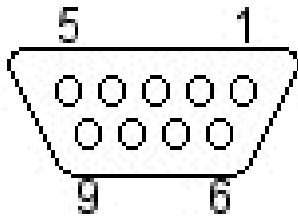

PIN.....	DESCRIPTION
1.....	V I/O
2.....	5 V
3.....	IN 2
4.....	START
5.....	GND
6.....	IN 1
7.....	12 V
8.....	OUT 1
9.....	OUT 2

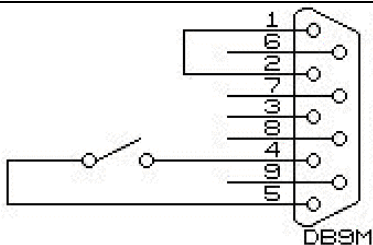

Using a **simple mechanical switch**.
Loop pins 1-2 and connect the switch between pins 4 and 5.

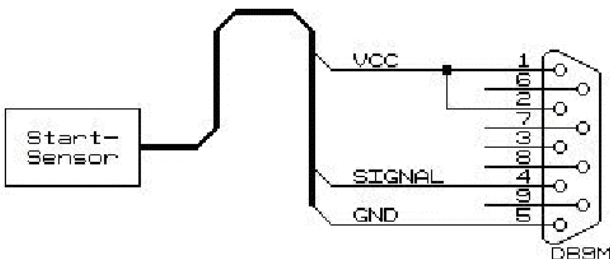

5 Volt NPN / PUSH/PULL sensor.
VCC to pins 1,2
Signal to pin 4
GND to pin 5

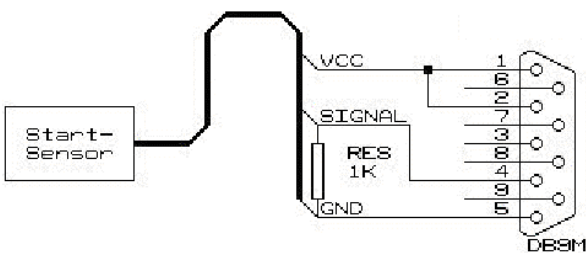

5 Volt PNP sensor.
VCC to pins 1,2
Signal to pin 4
GND to pin 5
1 K resistor between pin 4 and 5

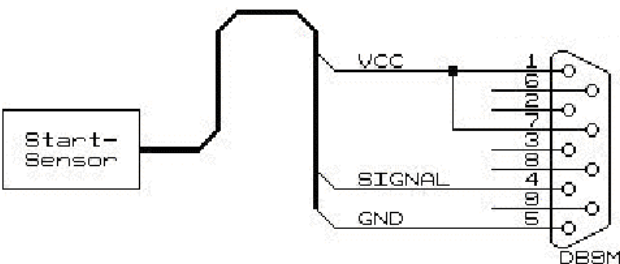

12 Volt NPN / PUSH/PULL
VCC to pins 1,7
Signal to pin 4
GND to pin 5

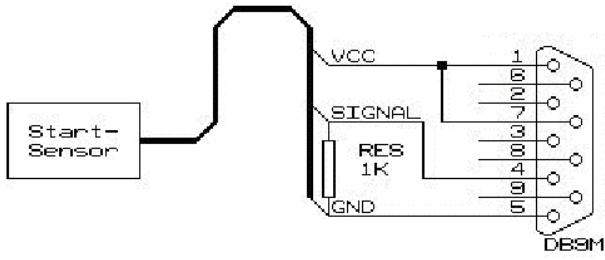

12 Volt PNP sensor.
VCC to pins 1,7
Signal to pin 4
GND to pin 5
1 K resistor between pin 4 and 5

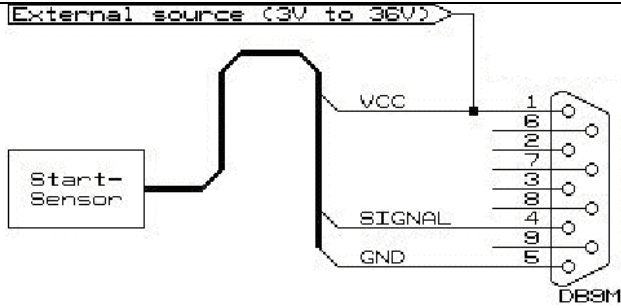

External power source, +3-36V, using NPN / PUSH/PULL sensor
VCC to pin 1
Signal to pin 4
GND to pin 5

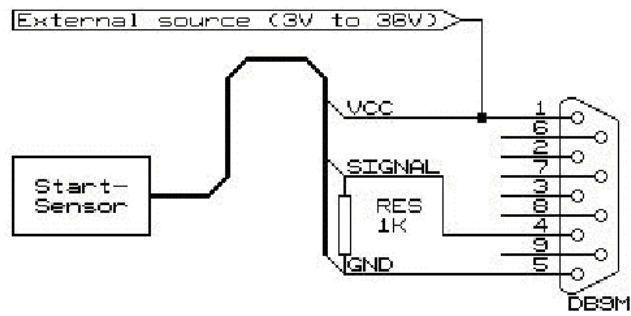

External power source, +3-36V, using PNP sensor
VCC to pin 1
Signal to pin 4
GND to pin 5
1K resistor between 4 and 5.

Encoder connections

For the encoder, you can use either a single or double channel. If you have both channels connected, you need to activate “Quadrature”, and divide distance / pulse by 4.

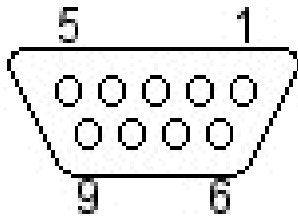

PIN.....	DESCRIPTION
1.....	V ENC
2.....	5 V
3.....	ENC A
4.....	ENC B
5.....	GND
6.....	
7.....	12 V
8.....	ENC A (inv.)
9.....	ENC B (inv.)

USING DOUBLE CHANNEL NPN OR PUSH/PULL ENCODER

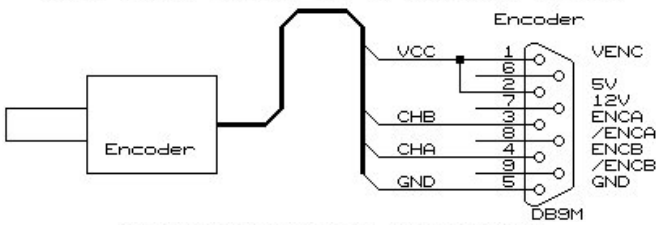

5 VOLT encoder double channel NPN / PUSH/PULL encoder

USING DOUBLE CHANNEL PNP ENCODER

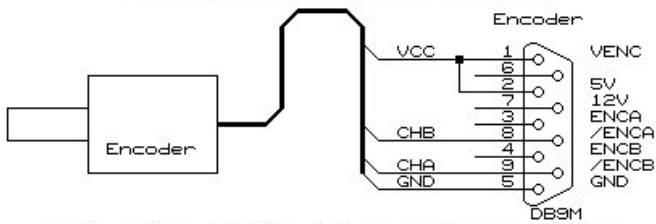

5 VOLT encoder double channel PNP encoder

USING SINGLE CHANNEL NPN OR PUSH/PULL ENCODER

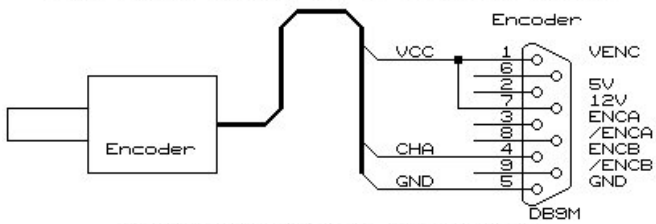

12 VOLT encoder single channel NPN/ PUSH/PULL encoder

USING SINGLE CHANNEL PNP ENCODER

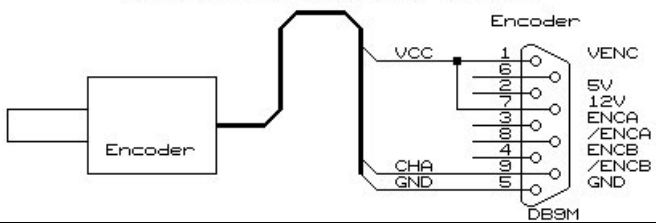

12 VOLT encoder single channel PNP encoder

USING DOUBLE CHANNEL NPN OR PUSH/PULL ENCODER

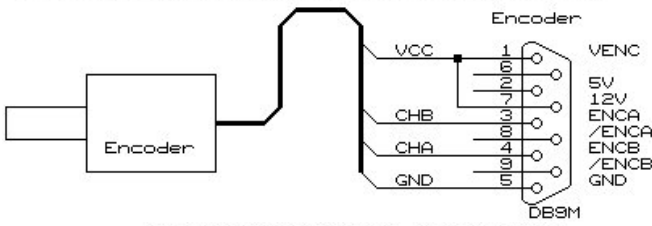

12 VOLT encoder double channel NPN / PUSH/PULL encoder

USING DOUBLE CHANNEL PNP ENCODER

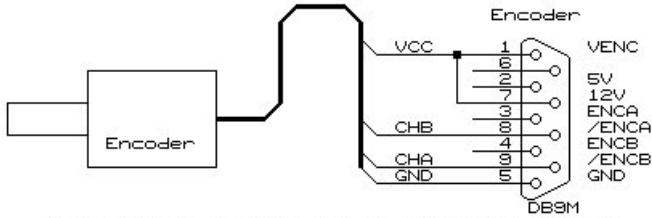

12 VOLT encoder double channel PNP encoder

USING SINGLE CHANNEL NPN OR PUSH/PULL ENCODER

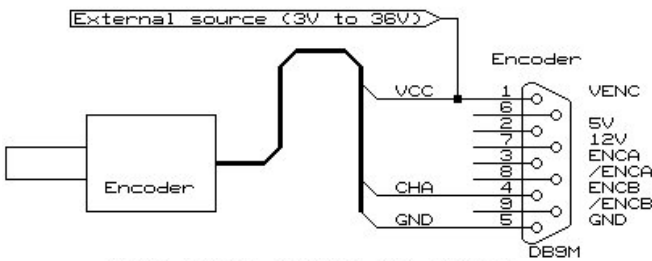

External power source, 3-36V, encoder single channel NPN/ PUSH/PULL encoder

USING SINGLE CHANNEL PNP ENCODER

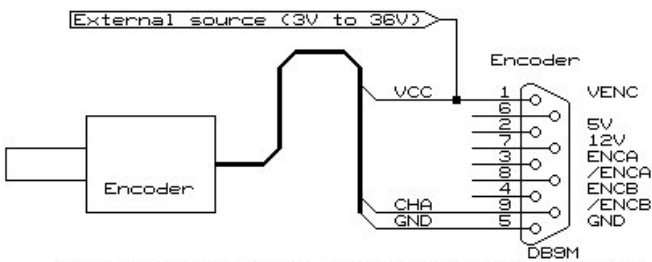

External power source, 3-36V, encoder single channel PNP encoder

USING DOUBLE CHANNEL NPN OR PUSH/PULL ENCODER

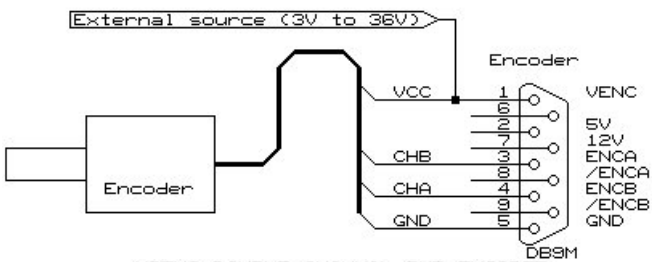

External power source, 3-36V, encoder double channel NPN / PUSH/PULL encoder

USING DOUBLE CHANNEL PNP ENCODER

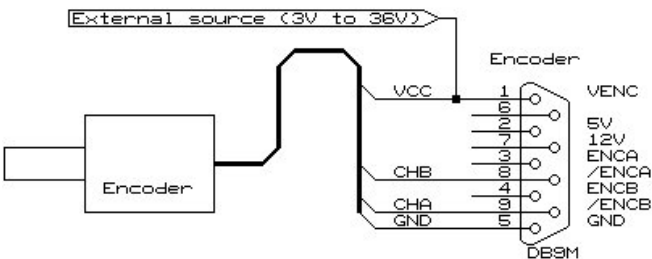

External power source, 3-36V, encoder double channel PNP encoder

Connecting external Signals to the CU

As can be seen from above diagrams, it is possible to connect external signals to the CU.

There are two output channels (OUT 1 and OUT 2), which can be configured by the user (see page 31).

Output 1

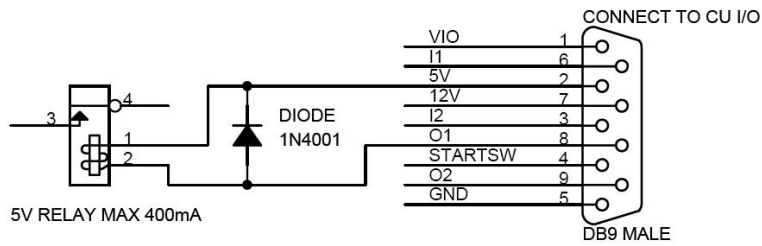

Relay, 5 V

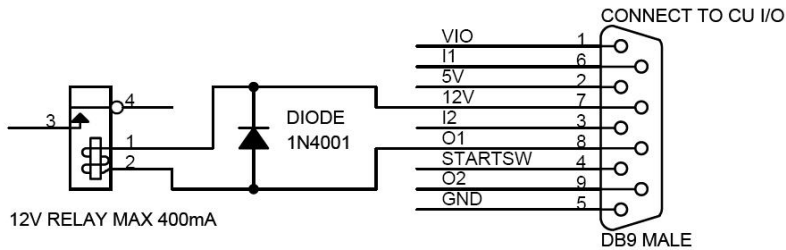

Relay 12 V

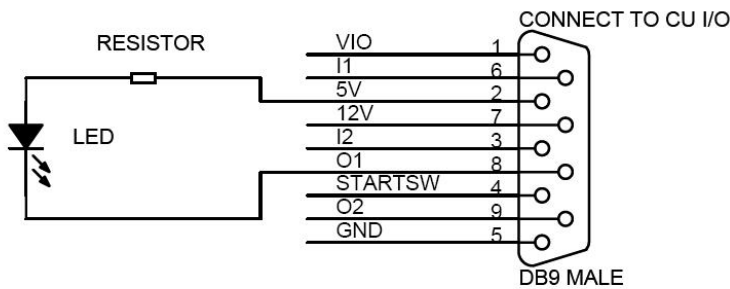

LED

$$\text{RESISTOR} = (5V - \text{LEDvoltage}) / \text{LEDcurrent}$$

Output 2

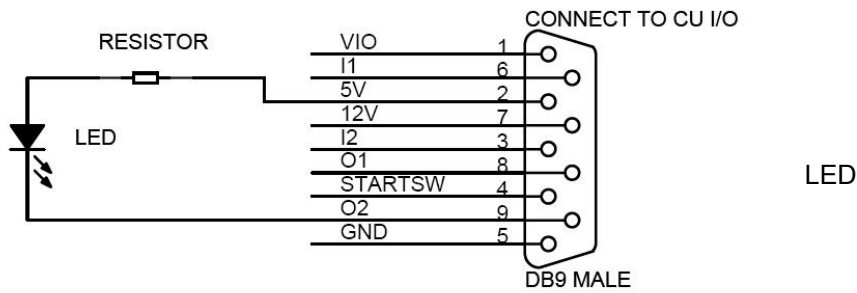
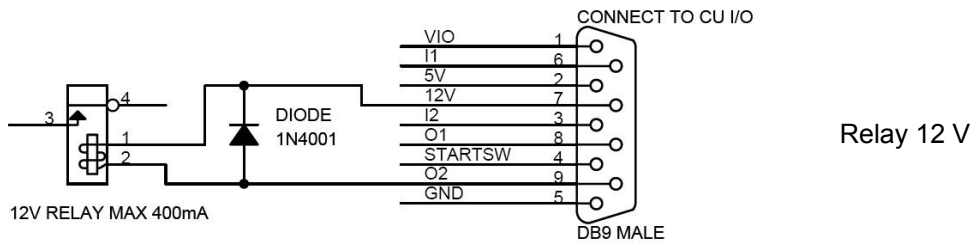
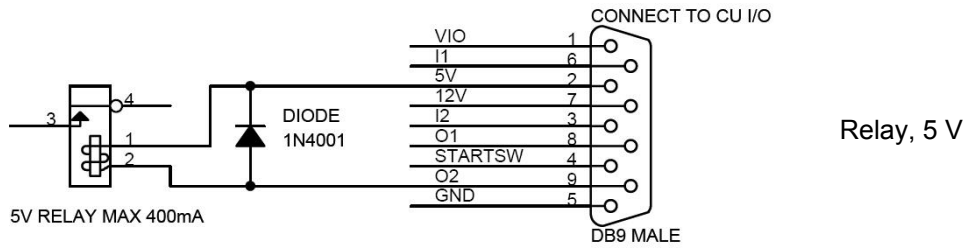

$$\text{RESISTOR} = (5V - \text{LEDvoltage}) / \text{LEDcurrent}$$

Complete remote control protocol

As previously mentioned, the CU remote commands is based on a dialog protocol, where you send commands and receive response back from the CU. Each command and response is always separated by "#".

It may be helpful to know **that the CU objects are grouped into numeric types, and then again by numbers.**

For example for counters (object type 1), you may have objects 1;1 1;2 and 1;3 for the 3 counters in your message. Additionally, objects have a descriptive name which you can read from the unit but NOT use to address objects. It is recommended that you after connecting to the unit ask which objects are available.

COMMAND

CMD:<parameters>#

Command is used to make the unit do something basic

Parameters	Description	Response
S	Stop print mode	RES:0#
R	Start print mode	RES:0#
F;<filename>	Load file (max 8 upper case chars). File must be present on the compact flash card.	RES:0#
D	Disconnect (PC network only)	RES:0#
U	Update next print buffer	RES:0#
C;<password>	Remote Connect with password (PC network only), not serial.	RES:10#
P	Purges all engines for 0,3 seconds	RES:0#
I;<1 2 3 4>	Ink counter reset for stall number 1..4. Only on HP version. Number must be 1,2,3 or 4.	RES:0#

REQUEST**REQ:<parameters>#**

Request is used to get information about the message currently loaded.

Parameters	Description	Response
object list	Read objects list	DAT:<object type>;<object nr>;<object name>#(all)RES:0#
dir	Read CU files list	DAT:<filename1># DAT:<filename2>...(all)RES:0#
object data;<object type>;<object nr>	Read data of specific object.	See OBJECT DATA RESPONSE
parameters	Read CU device parameters	See PARAMETERS RESPONSE
status	Read CU device status	See STATUS RESPONSE
device name	Read device name	DAT:device name;<device name>#RES:0#
version	Read version information	DAT:<release>;<upver.>;<fpgaver.>;<enetver.>#RES:0#
wait next	Return response when next print is started. Used as interrupt for next print.	RES:0#

<object type> : 0 = Text, 1 = Counter, 2 = Time, 3 = Date, 4 = Barcode, 5 = Logo object.

CHANGE OBJECT

OBJ:<object type>; <object nr>; <parameter>; <value>#

Set object is used to manipulate objects in the loaded message. For object type, please see above.

Parameters	Description	Allowed Values (Response = RES:0#)
activate / deactivate	activate or deactivate object.	none
TEX;<text>	Set text of text objects.	Text string max 80 chars.
MIN;<value>	Set minimum count of counter objects.	integer value (32 bit)
CUR;<value>	Set current count of counter objects.	integer value (32 bit)
MAX;<value>	Set maximum count of counter objects.	integer value (32 bit)
DIG;<value>	Set number of digits in counter objects.	integer value (32 bit)
DIR;<+/->	Set direction of counter objects.	<+> : count up. <-> : count down.
LDN;<0/1>	Set leadin of counter objects.	<0> : leadin with zeroes. <1> : blank leadin.
REP;<value>	Set repeats per count of counter objects.	integer value (0-255).
TIM;<value>	Set minutes offset of time objects.	integer value (signed)
DAT;<value>	Set day offset of date objects.	integer value (signed)
FOR;<value>	Set format of time/date objects.	Format string.
TYP;<value>	Set symbology of barcode objects.	1=code128, 2=code39, 3=ean13, 4=itf, 5=upc, (6=ean128)

SET PARAMETERS

PAR:<parameter>; <value>#

Set parameter is used to modify the print parameters of the unit.

Parameters	Description	Allowed Values (Response = RES:0#)
start;<value>	Set start distance.	integer value in mm.
edge;<+/->	Set startswitch edge.	<+> : positive edge. <-> : negative edge.
endless;<+/->	Set endless print mode.	<+> : endless print.
mode;<vel/pos>	Set encoder mode.	<vel> : set velocity mode. <pos> : set position mode.
encoder;<value>	Set encoder value.	integer value in 1/100000 mm/encoder pulses.
velocity;<value>	Set velocity value.	integer value in m/sec.
dir;<value>	Set direction.	0 = LEFT. 1 = RIGHT

FILE

FIL:<parameters>#

<file> (after receiving response to send)

Parameters	Description	Response
N;<filename>;<file extension>;<file size>	Initialize new file transmission to CF card in CU unit.	FIL:G;<filename>#
	Send file data after FIL:G response	RES:0#

PING (only Ethernet connections)

PNG:<parameters>#

Parameters	Description	Response
CU	Ping the CU, for broadcast on port 1600.	<PNG:CU#000(10 bytes)><IP ADDRESS(4 bytes)><ENET VERSION(4 bytes)><0xFFFF>

OBJECT DATA RESPONSE

This is the response you get on REQ:object data

Object type	Responses	parameters
All		active, name, font, prompt, locked, layer
Text		text
Counter	DAT:<parameters>;<value>#	decimals, counter, direction, leadin, maxcount, mincount, countstep, repeats
Time	... (RES:0# after last DAT response)	format, minoffset
Date		format, dayoffset, houroffset
Barcode		content, objtype, objnr, symbology, modul

PARAMETERS RESPONSE

This is the response you get on REQ:parameters#

Responses	parameters
DAT:<parameters>;<value># ... (RES:0# after last DAT response)	startdelay, startedge, direction, upsidedown, otherside, spitdelay, spitlength, tickle, repeatnr, repeatdis, endless, firemode, modular, position, qudrature, velocity

STATUS RESPONSE

This is the response you get on REQ:status#

Responses	parameters
DAT:<parameters>;<value># ... (RES:0# after last DAT response)	printactive, selectedfile, printcount, systeme, inklow

RESPONSES FROM CU

Error number	Error Description
0	No errors
1	Wrong password
2	Unknown command
10	Password accepted (ethernet only, not error)
11	Not connected (ethernet only. To connect use CMD:C;<password>#)
21	FIL: File not found / CF card full
24	File name error (use upper letters or numbers only)
100	CMD: Unknown command
101	Printer is not running
102	Printer is running
103	File not found
106	Printer active
200	Unknown request
300	Object not found
301	OBJ: Unknown or missing parameter
320	OBJ: illegal data
1000	PAR: Unknown or missing parameter
1020	PAR: Illegal edge
1040	PAR: Illegal data
1050	PAR: Illegal mode

Drawings of the CU

